

**THANK YOU** for purchasing this product



### REGISTER YOUR PURCHASE

 [ninjakitchen.co.uk/registerguarantee](https://ninjakitchen.co.uk/registerguarantee)

 Scan QR code using mobile device

### RECORD THIS INFORMATION

Model Number: \_\_\_\_\_

Serial Number: \_\_\_\_\_

Date of Purchase: \_\_\_\_\_  
(Keep receipt)

Store of Purchase: \_\_\_\_\_

### TECHNICAL SPECIFICATIONS

Voltage: 220-240V- 50-60Hz

Power: 2400W

### PRODUCT REGISTRATION:

Please visit [ninjakitchen.co.uk](https://ninjakitchen.co.uk) or call 0800 862 0453 to register your new Ninja® product within 28 days of purchase. You will be asked to provide the store name, date of purchase and model number along with your name and address.

The registration will enable us to contact you in the unlikely event of a product safety notification.

**SharkNinja Europe Limited,**  
3150 Century Way,  
Thorpe Park,  
Leeds,  
LS15 8ZB, UK  
[ninjakitchen.co.uk](https://ninjakitchen.co.uk)

**SharkNinja Germany GmbH,**  
c/o Regus Management GmbH,  
Excellent Business Center 10.+11. Stock,  
Westhafenplatz 1,  
60327 Frankfurt am Main, Germany  
[ninjakitchen.eu](https://ninjakitchen.eu)

Illustrations may differ from actual product. We are constantly striving to improve our products, therefore the specifications contained herein are subject to change without notice.

NINJA is a registered trademark in the United Kingdom of SharkNinja Operating LLC.

NINJA WOODFIRE is a pending application in the United Kingdom of SharkNinja Operating LLC.

© 2022 SharkNinja Operating LLC

OG701UK\_Series\_IB\_MP\_221216\_Mv1



[ninjakitchen.co.uk](https://ninjakitchen.co.uk)

## NINJA WOODFIRE ELECTRIC BBQ GRILL & SMOKER OG701UK | Instructions



## IMPORTANT SAFETY INSTRUCTIONS

**OUTDOOR HOUSEHOLD USE ONLY. READ ALL INSTRUCTIONS BEFORE USE**



Read and review instructions to understand operation and use of product.



Indicates the presence of a hazard that can cause personal injury, death or substantial property damage if the warning included with this symbol is ignored.



Avoid contact with hot surface. Always use hand protection to avoid burns.



For outdoor use only.



Resistant to water splash from any direction.

**⚠ WARNING** Failure to follow these instructions could result in electric shock, fire or burn hazard which could cause property damage, personal injury, or death. When using electrical appliances, basic safety precautions should always be followed, including the following:

- 1 To eliminate a choking hazard for young children, discard all packaging materials immediately upon unpacking.
- 2 This appliance is for outdoor household use only. **DO NOT** use this appliance for anything other than its intended use. **DO NOT** use in moving vehicles or boats. Misuse may cause injury.
- 3 **DO NOT** use indoors. This grill is designed for **OUTDOOR USE ONLY** in a well-ventilated area. If used under any overhead cover, toxic fumes, including carbon monoxide, may accumulate and cause serious bodily injury or death.
- 4 This appliance can be used by persons, including children, with reduced physical, sensory, or mental capabilities or lack of experience and knowledge if they have been given supervision or instruction concerning use of the appliance in a safe way and understand the hazards involved.
- 5 **ALWAYS** ensure the appliance is properly assembled before use. **DO NOT** use without side handles attached.
- 6 To avoid property damage from flame or heat maintain a minimum distance of 92cm (3 feet) from rear, sides and top to walls, rails or other combustible constructions.
- 7 Ensure the surface is level, stable, clean and dry. **DO NOT** place the appliance near the edge of the surface the grill is placed on during operation.
- 8 Children should be supervised to ensure that they do not play with the appliance. **Keep** the appliance and its cord out of reach of children. **DO NOT** allow the appliance to be used near, cleaned or maintained by children.
- 9 The appliance should be supplied through a residual current device (RCD) having a rated residual operating current not exceeding 30mA. The appliance is to be connected to a socket-outlet having an earthing contact.
- 10 A short power-supply cord is provided to reduce the risk of children less than 8 years grabbing the cord or becoming entangled and to reduce the risk of people tripping over a longer cord. **SUITABLE FOR USE WITH OUTDOOR APPLIANCES.** Longer detachable power-supply cord or extension cords are available and may be used if care is exercised in their use.
- 11 To avoid property damage and burn injury from flame or heat, **ALWAYS** maintain a minimum safe distance of at least 1 foot (30 cm) from the pellet box during smoking. Small flames can come out from the pellet box if the grill lid is lifted in windy conditions.
- 12 To avoid burn injury, **ALWAYS** use pellet scoop when adding pellets to smoker box. **DO NOT** add pellets by hand.
- 13 To avoid burn injury and property damage, make sure the lid of the smoke box is fully closed to prevent flames from escaping out of the smoke box.
- 14 Pellets may continue to burn after cook time is complete. Do not touch or remove the smoke box until the grill has stopped smoking, pellets have completely burnt out and the smoke box has cooled.
- 15 To avoid personal injury and burns allow to cool before cleaning, disassembly, putting in or taking off parts and storage.

# IMPORTANT SAFETY INSTRUCTIONS

PLEASE READ CAREFULLY BEFORE USE • FOR HOUSEHOLD USE ONLY

- 16 **DO NOT** allow pellets to overflow the pellet box. Doing so will introduce oxygen leading to combustion, flame and damage to the unit which may result in burn injury.
- 17 **DO NOT** touch hot surfaces. Appliance surfaces are hot during and after operation. To prevent burns or personal injury, **ALWAYS** use protective hot pads or insulated oven gloves and use available handles and knobs.
- 18 **DO NOT** touch accessories during or immediately after cooking. The basket will become extremely hot during the cooking process. Avoid physical contact while removing the accessory from the appliance. To prevent burns or personal injury **ALWAYS** use care when using with product. We recommend use of long handed utensil and protective hot pads or insulated oven gloves.
- 19 **ALWAYS** ensure the grill is completely cool before releasing and removing the cooking plates or moving the to avoid burns or personal injury.
- 20 **DO NOT** use the appliance without the grill plate installed.
- 21 To protect against electric shock, cord and extension cord should be arranged so that they will not drape over the worktop or table top where they can be pulled on by children or tripped over. Keep the cord connection dry and **DO NOT** immerse cord, plugs or main unit housing in water or other liquid.
- 22 Regularly inspect the appliance and power cord. **DO NOT** use the appliance if there is damage to the power cord or plug. If the appliance malfunctions or has been damaged in any way, immediately stop use and call Customer Service.
- 23 **NEVER** use socket below worktop surface.
- 24 **NEVER** connect this appliance to an external timer switch or separate remote-control system.
- 25 **DO NOT** place appliance and let cord touch hot surfaces.
- 26 Only use recommended accessories included with this appliance or authorised by SharkNinja. The use of accessories or attachments not recommended by SharkNinja may cause a risk of fire or injury.
- 27 Before placing any accessory into the cooker, ensure it is clean and dry.
- 28 **DO NOT** move the appliance when in use.
- 29 **DO NOT** cover the air intake vent or air outlet vent while unit is operating. Doing so will prevent even cooking and may damage the unit or cause it to overheat.
- 30 **DO NOT** place anything on top of the product when the lid is closed during use.
- 31 Ensure the grill plate is correctly inserted and securely locked into position.
- 32 **DO NOT** use this appliance for deep-frying.
- 33 Some foods may cause oils or grease to splash. Use care when opening the grill to avoid burns.
- 34 Should a grease fire occur or the unit emits black smoke, unplug immediately. Wait for smoking to stop before removing any cooking accessories.
- 35 Socket voltages can vary, affecting the performance of your product. To prevent possible illness, **ALWAYS** use an external food thermometer to check that your food is cooked to the recommended temperatures.
- 36 Use **ONLY** genuine food grade wood pellets from Ninja in your unit.
- 37 **NEVER** use heating fuel pellets, hardwood, charcoal, liquid fuels or any other combustible material in the Smoker.
- 38 Keep hands and face away from Smoker Box when unit is in use and hot.
- 39 **ALWAYS** keep a fire extinguisher suitable for electrical fires accessible while operating the smoker.
- 40 **ALWAYS** store wood pellets in a dry location, away from heat-producing appliances and other fuel containers.
- 41 Keep your grill clean and do not allow excess grease or ash to collect inside or on the smoke box and cartridge. Doing so significantly increases the chances of a grease fire and additional smoke which can taint the flavour of your food.
- 42 Please refer to the Cleaning & Maintenance section for regular maintenance of the appliance.
- 43 To disconnect, press the power button to turn the unit off, then unplug from socket when not in use and before cleaning.
- 44 **DO NOT** clean this product with a water spray or the like.
- 45 **DO NOT** clean with metal scouring pads. Pieces can break off the pad and touch electrical parts, creating a risk of electric shock.
- 46 Store indoors when not in use - out of reach of children.
- 47 **DO NOT** keep uncovered grill exposed to elements. **ALWAYS** use grill cover when stored outdoors.

## SAVE THESE INSTRUCTIONS.

## PARTS & ACCESSORIES

- A Grill Plate
- B Crisper Basket
- C Smoke Box (pre-installed)
- D Grease Tray
- E Left and Right Assembly Handles
- F Socket Head Cap Screw 3.5mm x 16mm (4x) (pre-assembled on handles)
- G Hex Key
- H Pellet Scoop
- I Assembled Main Unit (power cord not shown)
- J Lid
- K Control Panel
- L ON/OFF Switch

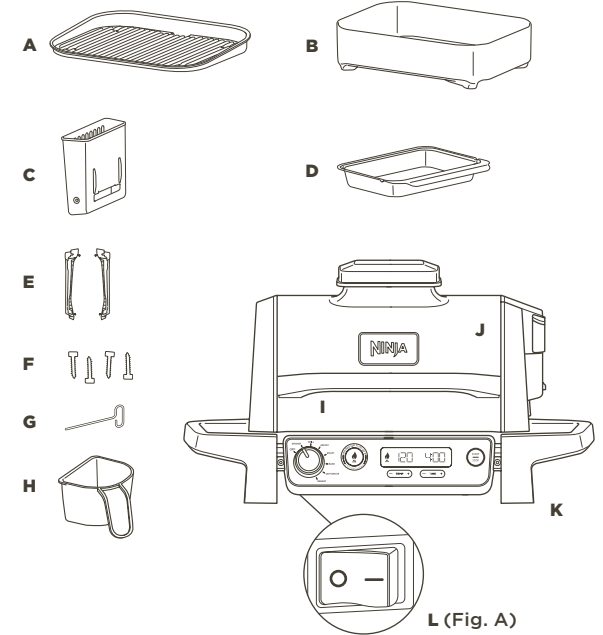

To order replacement or additional parts and accessories, visit [ninjakitchen.co.uk](http://ninjakitchen.co.uk)

## BEFORE FIRST USE

- 1 Remove and discard any packaging material and tape from the unit. Some stickers are to be permanently kept on the unit, **ONLY** remove stickers with 'peel here'.
- 2 Remove all accessories from the package and read this manual carefully. Please pay particular attention to operational instructions, warnings and important safeguards to avoid any injury or property damage.
- 3 Wash the grill plate and crisper basket in warm, soapy water, then rinse and dry thoroughly. The grill plate, crisper basket and base unit are **NOT** dishwasher safe. **NEVER** clean the main unit in the dishwasher. **NOTE:** The base liner underneath the bottom heating element may have some visible discoloration. This is a result of our normal manufacturing process. The unit has not been previously used.
- 4 **DO NOT** use abrasive brushes or sponges on the cooking surfaces, as they will cause damage to the coating
- 5 Plug into electrical socket and press the switch located underneath the left side of the control panel to the ON position. (See Fig. A above).
- 6 To turn your product off, ensure the dial is rotated to the OFF position and the press switch is OFF.

**NOTE:** If unit won't turn on, check the residual current device (RCD) is fully plugged in and the reset button has been pressed.

We recommend placing all accessories inside the grill and running it on GRILL, temp set to HI for 20 minutes without adding food. This removes any residues. This is completely safe and not detrimental to the performance of the grill.

## BEFORE FIRST USE - CONTINUED

### HANDLE INSTALLATION

- 1 Ensure the correct handle is being used on the left and right side. (Refer to Fig. A and note that the handles have L and R stickers on the underside). A Hex key is taped onto the left handle (see Fig. A).
- 2 Place unit at edge of table (Fig. B) OR with lid still taped down, carefully place grill upside down by holding the sides of the unit and the lid down. If tape has been removed, remove all accessories from the grill and holding the sides of the unit and the lid down, place grill on top of top pulp tray piece to protect unit (Fig. C).
- 3 Align each handle with tabs on base, then push up to set each handle in place (Fig. D). Use included Hex key to tighten pre-assembled screws (2x) on each handle (Fig. E).

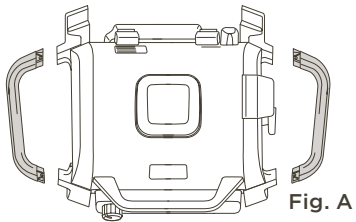

Fig. A

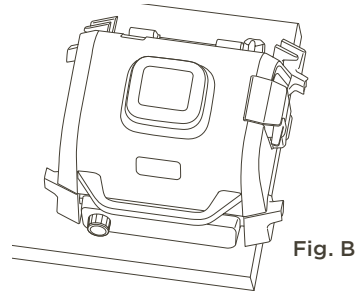

Fig. B

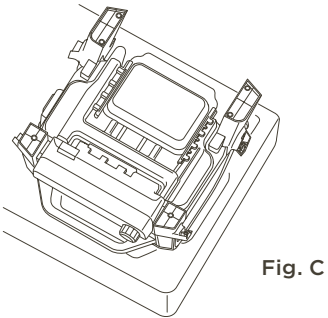

Fig. C

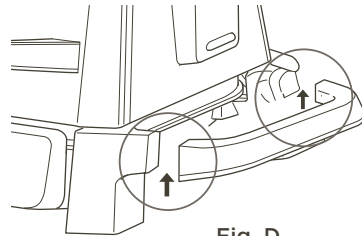

Fig. D

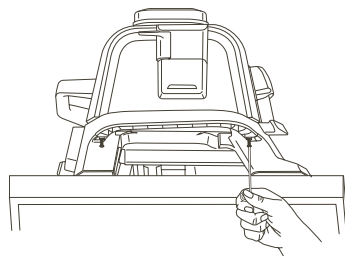
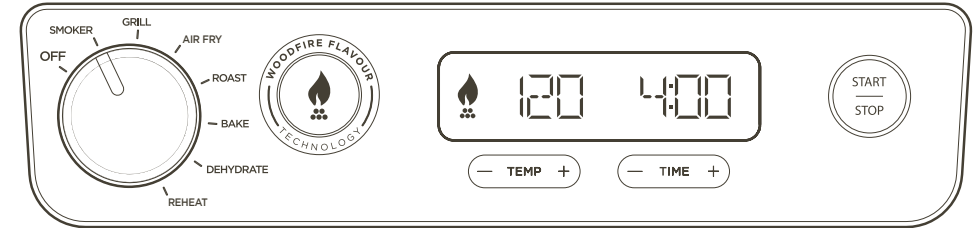

Fig. E

### EXTENSION CORD

- 1 If using an extension cord, ensure it is suitable for use outdoors with outdoor appliances. Using the incorrect cord could lead to the cord overheating, melting and/or a drop in voltage. A drop in voltage can increase preheat times and impact cooking performance and/or cook times.

## GETTING TO KNOW THE WOODFIRE ELECTRIC BBQ GRILL & SMOKER



### FUNCTION BUTTONS

There are 2 ways to achieve authentic smokey BBQ flavours:

1. Dedicated **SMOKER** program for cooking over a longer period of time for deep flavours and tender results.
2. Add a quick burst of Woodfire Flavour to any of the other functions, except **REHEAT**, using the **WOODFIRE FLAVOUR TECHNOLOGY** button.

**SMOKER:** Create deep, smoky flavours while cooking low and slow to tenderise large cuts of meat.

**GRILL:** Closed-lid cooking for top and bottom heat. Best when grilling large or thick cuts of meat or frozen food or for an all-around sear. Open the lid while grilling delicate foods or lean proteins to develop chargrilled textures without overcooking.

**AIR FRY:** Achieve crispiness and crunch with little to no oil and higher fan speeds.

**ROAST:** Tenderise meats, roast vegetables and more.

**BAKE:** Bake breads, cakes and more with lower fan speeds.

**DEHYDRATE:** Great for drying fruits, vegetables and jerky.

**REHEAT:** Ideal for reheating leftovers so nothing goes to waste.

**WOODFIRE FLAVOUR TECHNOLOGY:** Press after selecting your cooking function to add Woodfire Flavour using the Grill, Air Fry, Bake, Roast or Dehydrate functions. When pressed, flame icon will illuminate on the display screen.

### OPERATING BUTTONS

**DIAL:** To power on the unit and select a cooking function, rotate the dial clockwise until desired function is selected. To power off the unit, rotate the dial anti-clockwise to the **OFF** position.

**NOTE:** When the unit is powered on, the display will be illuminated.

**TEMP:** The default temperature setting will display, to adjust temperature if desired, use the - and + buttons next to TEMP.

**TIME:** To adjust cook time, use the - and + buttons next to TIME.

**START/STOP:** Press to start or stop the current cook function or press and hold for 3 seconds to skip preheat.

### PREHEAT FOR BETTER RESULTS

For best grilling results, let the unit fully preheat before adding food. Adding food before preheating is complete may lead to overcooking, smoke and longer preheat time.

After you set function, time and temperature then press **START**, the unit will automatically begin preheating (except if using the Smoker function or the Reheat/Dehydrate functions) without enabling Woodfire Flavour technology.

## REMOVABLE SMOKE BOX

The smoke box comes fully installed in the unit and is located on the right side of the lid. Always ensure the removable smoke box is inserted into place before adding pellets. Review all warnings before proceeding.



### Installing the smoke box:

To install, hold the smoke box lid open with one hand and insert the removable smoke box so it sits into place.



### Adding Ninja Woodfire Pellets:

Fill the pellet scoop to the top and level off to avoid spilling. While holding the smoke box lid open, pour pellets into the smoke box until filled to the top, then close the smoke box lid. Ensure the lid is properly closed before cooking.

Use only Ninja Woodfire Pellets for best results, performance and flavour.



### Removing the smoke box and cleaning:

To avoid burns, allow pellets to completely burn and smoke box to cool completely, then remove smoke box and safely discard all contents.

## COOKING FUNCTIONS

Plug in the unit and press the switch located underneath the left side of the control panel to the ON position.

**IMPORTANT: Review all important safety instructions before use.**



### Smoker

**NOTE:** The temperature is preset to 120°C.

- Place grill on a flat, level surface.
- Open the lid and install the grill plate by positioning it flat on top of the heating element so it sits into place.
- Install the grease tray by sliding it into place at the back of the grill.
- Lift the smoke box lid and using the pellet scoop, fill the smoke box with pellets to the top, then close the lid. **DO NOT** overfill smoke box.
- Open the lid and place ingredients on the grill plate. Close the lid.
- Make sure the grill is plugged in and rotate the dial clockwise from the **OFF** position to select the **SMOKER** function.
- The default temperature setting will display. Use the - and + buttons next to **TEMP** to choose a temperature from 120°C to 210°C in 10 degree increments.

- Use the - and + buttons next to **TIME** to adjust cook time from 1 minute to 30 minutes, in 1 minute increments and from 30 minutes to 12 hours in 15 minute increments.
- Press **START** to begin cooking. There is no preheat time for the Smoker function.
- When cook time reaches zero, the unit will beep and **END** will appear on the display.
- Remove food from the grill plate.

## COOKING FUNCTIONS - CONTINUED

**IMPORTANT: Review all important safety instructions before use.**

### Grill

**NOTE:** The temperature is preset to HI.

- Place grill on a flat, level surface.
- Open the lid and install the grill plate by positioning it flat on top of the heating element so it sits into place.
- Install the grease tray by sliding it into place at the back of the grill.
- If you plan to use the Woodfire Flavour technology, lift the smoke box lid and using the pellet scoop, fill the smoke box with pellets to the top, then close the lid. **DO NOT** overfill smoke box.
- Make sure the grill is plugged in and rotate the dial clockwise from the **OFF** position to select the **GRILL** function.
- If adding Woodfire Flavour technology, press the **WOODFIRE FLAVOUR** technology button.
- The default temperature setting will display. Use the - and + buttons next to **TEMP** to choose a temperature from LO to HI.
- Use the - and + buttons next to **TIME** to adjust cook time in 1 minute increments up to 1 hour.
- Press **START** to begin preheating. If using Woodfire Flavour technology, the pellets will go through an ignition cycle (IGN), then the grill will begin preheating (PRE).

**NOTE:** While preheating is strongly recommended for best results, you can skip it by pressing and holding the **START/STOP** button for 4 seconds. "ADD FOOD" will flash across the screen. Open the lid and place ingredients on the grill plate. Once the lid is closed, cooking will begin and the timer will start counting down. Skip to step 11 for further instructions.

- When preheating is complete, the unit will beep and **ADD FOOD** will appear on the display.
- Open the lid and place ingredients on the grill plate. Once the lid is closed, cooking will begin and the timer will begin counting down.
- When cook time reaches zero, the grill will beep and **DONE** will appear on the display.
- Remove food from the grill plate.

### Air Fry

**NOTE:** The temperature is preset to 200°C.

- Place grill on a flat, level surface.
- Open the lid and install the grill plate by positioning it flat on top of the heating element so it sits into place.
- Place the crisper basket on the grill plate and position the basket feet into the designated indentations on the grill plate surface.
- Install the grease tray by sliding it into place at the back of the grill.
- If you plan to add Woodfire Flavour, lift the smoke box lid and using the pellet scoop, fill the smoke box with pellets to the top, then close the lid. **DO NOT** overfill smoke box.
- Make sure the grill is plugged in and rotate the dial clockwise from the **OFF** position to select the **AIR FRY** function.
- If adding Woodfire Flavour, press the **WOODFIRE FLAVOUR** technology button.
- The default temperature setting will display. Use the - and + buttons next to **TEMP** to choose a temperature from 150°C to 240°C in 10 degree increments.
- Use the - and + buttons next to **TIME** to adjust cook time in 1 minute increments up to 1 hour.
- Press **START** to begin preheating. If using Woodfire Flavour technology, the pellets will go through an ignition cycle (IGN), then the grill will begin preheating (PRE).

**NOTE:** While preheating is strongly recommended for best results, you can skip it by pressing and holding the **START/STOP** button for 4 seconds. "ADD FOOD" will flash across the screen. Open the lid and place ingredients in the crisper basket. Once the lid is closed cooking will begin and the timer will start counting down. Skip to step 12 for further instructions.



- When preheating is complete, the unit will beep and **ADD FOOD** will appear on the display.
- Open the lid and place ingredients on the grill plate. Once the lid is closed, cooking will begin and the timer will begin counting down.
- When cook time reaches zero, the unit will beep and **END** will appear on the display.
- Remove food from the crisper basket.

## COOKING FUNCTIONS - CONTINUED

**IMPORTANT:** Review all important safety instructions before use.

### Roast

**NOTE:** The temperature is preset to 180°C.



- 1 Place grill on a flat, level surface.
- 2 Open the lid and install the grill plate by positioning it flat on top of the heating element so it sits into place.
- 3 Install the grease tray by sliding it into place at the back of the grill.
- 4  If you plan to add Woodfire Flavour, lift the smoke box lid and using the pellet scoop, fill the smoke box with pellets to the top, then close the lid. **DO NOT** overfill smoke box.
- 5 Make sure the grill is plugged in and rotate the dial clockwise from the **OFF** position to select the **ROAST** function.
- 6  If adding Woodfire Flavour, press the **WOODFIRE FLAVOUR** technology button.
- 7 The default temperature setting will display. Use the - and + buttons next to **TEMP** to choose a temperature from 160°C to 220°C in 10 degree increments.
- 8 Use the - and + buttons next to **TIME** to adjust cook time from 1 minute to 1 hour, in 1 minute increments and from 1 hour to 2 hours in 5 minute increments.
- 9 Press **START** to begin preheating. If using Woodfire Flavour technology, the pellets will go through an ignition cycle (IGN), then the grill will begin preheating (PRE).
- 10 When preheating is complete, the unit will beep and **ADD FOOD** will appear on the display.

**NOTE:** While preheating is strongly recommended for best results, you can skip it by pressing and holding the **START/STOP** button for 4 seconds. "**ADD FOOD**" will flash across the screen. Open the lid and place ingredients in the crisper basket. Once the lid is closed cooking will begin and the timer will start counting down. Skip to step 12 for further instructions.

- 11 Open the lid and place ingredients on the grill plate. Once the lid is closed, cooking will begin and the timer will begin counting down.
- 12 When cook time reaches zero, the unit will beep and **END** will appear on the display.
- 13 Remove food from grill plate.

### Bake

**NOTE:** The temperature is preset to 160°C.

- 1 Place grill on a flat, level surface.
- 2 Open the lid and install the grill plate by positioning it flat on top of the heating element so it sits into place.
- 3 Install the grease tray by sliding it into place at the back of the grill.
- 4  If you plan to add Woodfire Flavour, lift the smoke box lid and fill the smoke box with pellets to the top, then close the lid. **DO NOT** overfill smoke box.
- 5 Make sure the grill is plugged in and rotate the dial clockwise from the **OFF** position to select the **BAKE** function.
- 6  If adding Woodfire Flavour, press the **WOODFIRE FLAVOUR** technology button.
- 7 The default temperature setting will display. Use the - and + buttons next to **TEMP** to choose a temperature from 120°C to 210°C in 10 degree increments.
- 8 Use the - and + buttons next to **TIME** to adjust cook time from 1 minute to 1 hour, in 1 minute increments and from 1 hour to 4 hours in 5 minute increments.
- 9 Press **START** to begin preheating. If using Woodfire Flavour technology, the pellets will go through an ignition cycle (IGN), then the grill will begin preheating (PRE).
- 10 When preheating is complete, the unit will beep and **ADD FOOD** will appear on the display.

**NOTE:** While preheating is strongly recommended for best results, you can skip it by pressing and holding the **START/STOP** button for 4 seconds. "**ADD FOOD**" will flash across the screen. Open the lid and place ingredients in the crisper basket. Once the lid is closed cooking will begin and the timer will start counting down. Skip to step 12 for further instructions.

- 11 Open the lid and place ingredients on the plate or place bake pan on the plate. Once the lid is closed, cooking will begin and the timer will start counting down.
- 12 When cook time reaches zero, the unit will beep and **END** will appear on the display.
- 13 Remove food from the grill plate.

**NOTE:** When using the Bake function, make sure to use the proper accessory. For wet or battered ingredients, use a baking dish. For loose items such as bread, pastries or biscuits, use the crisper basket.

**IMPORTANT:** Review all important safety instructions before use.

### Dehydrate

**NOTE:** The temperature is preset to 60°C.

- 1 Place grill on a flat, level surface.
- 2 Open the lid and install the grill plate by positioning it flat on top of the heating element so it sits into place.
- 3 Install the grease tray by sliding it into place at the back of the grill.
- 4 Open the lid and place ingredients on the grill plate. Close the lid. There is no preheat.
- 5 Make sure the unit is plugged in and rotate the dial clockwise from the **OFF** position to select the **DEHYDRATE** function.
- 6 The default temperature setting will display. Use the - and + buttons next to **TEMP** to choose a temperature from 40°C to 90°C in 10 degree increments.
- 7 Use the - and + buttons next to **TIME** to adjust cook time from 1 minute to 30 minutes, in 1 minute increments and from 30 minutes to 12 hours in 15 minute increments.
- 8 Press **START** to begin cooking.
- 9 When cook time reaches zero, the unit will beep and **END** will appear on the display.
- 10 Remove food from the grill.

#### USING WOODFIRE FLAVOUR TECHNOLOGY WITH DEHYDRATE

- To add Woodfire Flavour, after step 3, lift the smoke box lid and fill the smoke box with pellets to the top, then close the lid. **DO NOT** overfill smoke box.
- Skip step 4, follow steps 5-7 for programming. \*Press the **WOODFIRE FLAVOUR** button after you select **DEHYDRATE** in step 4.
- After step 7, press **START** to begin preheating. The pellets will go through an ignition cycle (IGN).
- When preheating is complete, the unit will beep and **ADD FOOD** will appear on the display.
- Open the lid and place ingredients on the grill plate. Once the lid is closed, cooking will begin and the timer will begin counting down.
- When cook time reaches zero, the unit will beep and **END** will appear on the display.
- Remove food from the grill plate.

### Reheat

**NOTE:** The temperature is preset to 170°C.

- 1 Place grill on a flat, level surface.
- 2 If required, place the crisper basket on the grill plate and position the basket feet into the designated indentations on the grill plate surface. Add ingredients, then close the lid.
- 3 Install the grease tray by sliding it into place at the back of the grill.
- 4 Make sure the grill is plugged in and rotate the dial clockwise from the **OFF** position to select the **REHEAT** function.
- 5 The default temperature setting will display. Use the - and + buttons next to **TEMP** to choose a temperature from 130°C to 210°C in 10 degree increments.
- 6 Use the - and + buttons next to **TIME** to adjust cook time in 1 minute increments up to 1 hour.
- 7 Press **START** to begin cooking (the unit does not preheat in Reheat mode).
- 8 Cooking will begin and the timer will begin counting down.
- 9 When cook time reaches zero, the unit will beep and **END** will appear on the display.
- 10 Remove food from the grill.



## CLEANING YOUR WOODFIRE ELECTRIC BBQ GRILL & SMOKER

The unit should be cleaned thoroughly after each use. **ALWAYS** let the appliance and accessories cool before cleaning.

- Unplug the unit from power source before cleaning. Keep the lid open after removing your food to allow the unit to cool quicker.
- Remove smoke box and safely discard cooled ash contents after every use.
- The pellet scoop is dishwasher safe. The grill plate, crisper basket, grease tray and smoke box are **NOT** dishwasher safe.
- Carefully remove cooled grease tray from the back of the unit. Safely discard grease contents and hand-wash grease tray in warm, soapy water.
- Before storage or when removing the grease tray, inspect the bottom of the unit for buildup of debris. Wipe with damp cloth. Do not use chemicals.

- Cleaning of the smoke box is not required. However if desired, a wire brush can be used to remove extra creosote.

**NOTE: DO NOT** use liquid cleaning solution on the smoke box.

- If food residue or grease is stuck on the grill plate or any other removable part, soak in warm, soapy water before cleaning.
- Remove non-stick grill plate and crisper basket (if used) after each use and hand-wash with warm, soapy water.

**NOTE: NEVER** use abrasive tools or cleaners. **NEVER** immerse the main unit in water or any other liquid. **DO NOT** place in dishwasher.

- When stacking the coated accessories to store, place a cloth or paper towel between each piece to protect the coated surfaces.

### CLEANING THE LID

- The inner lid should be wiped down with a damp towel or cloth after each use to deodorise the unit and remove any grease.
- Gently wipe down the inside of the lid with a damp cloth.

## TROUBLESHOOTING GUIDE

**⚠ WARNING: To reduce the risk of shock and unintended operation, turn power off and unplug unit before troubleshooting.**

- **“Add Grill” appears on the control panel display.**  
The grill plate needs to be installed. Once installed, close the lid and press the start button to begin.
- **“Add Food” appears on the control panel display.**  
The unit has completed preheating and it is now time to add your ingredients.
- **“Shut Lid” appears on the control panel display.**  
The lid is open and needs to be closed for the selected function to start.
- **“E” appears on the control panel display.**  
The unit is not functioning properly. Please contact Customer Service at 0800 862 0453. So we may better assist you, please register your product online at [ninjakitchen.co.uk](http://ninjakitchen.co.uk) and have the product on hand when you call.
- **My unit won't turn on?**
  - 1 Check the residual current device (RCD) is fully plugged in and the reset button has been pressed.
  - 2 Ensure the press switch is turned to the ON position.
  - 3 Make sure the dial is not in the OFF position.If your unit doesn't turn on after taking the steps above, please contact Customer Service at 0800 862 0453.
- **Should I add my ingredients before or after preheating?**  
For best results, let the unit preheat before adding ingredients.
- **Do I need to completely fill the smoke box with pellets?**  
Yes, always fill the smoke box to the top. We've perfected the amount of pellets needed for each smoke session, regardless of the function or food load, the unit will burn through them appropriately.

## TROUBLESHOOTING GUIDE

- **When do I press the Woodfire Flavour technology button?**  
Press the Woodfire Flavour technology button before pressing start when wanting to add smoke using the Grill, Air Fry, Roast, Bake or Dehydrate. You do not need to press the Woodfire Flavour technology button when using the Smoker function. We don't advise to use Woodfire Technology with reheat, as your food is already full of flavour.
- **Why are flames coming out from the pellet box?**  
Small flames can come out from the pellet box if the grill lid is lifted in windy conditions.
- **Where should I keep my pellets stored?**  
Always store pellets in a dry area. Any moisture in the pellets can compromise ignition and quality of smoke flavour.
- **Should I use any oils or non-stick sprays when smoking?**  
No, we do not recommend using any oils or non-stick sprays when smoking because smoke will not adhere to the food as well.
- **How do I dispose of burnt pellets after a cook cycle?**  
Pellets may continue to burn after cook time is complete. Do not touch or remove the smoke box until the grill has stopped smoking, pellets have completely burnt out and the smoke box has cooled. Then, remove the smoke box and safely discard cooled ash contents.
- **Why is preheat taking so long?**  
Preheat times vary by function and unit temperature.  
GRILL: approx. HI 8-12 | MED 6-11 | LO 5-9mins.  
AIR FRY, BAKE, ROAST: 3 minutes  
SMOKER, DEHYDRATE, REHEAT: No preheat.  
If adding Woodfire Flavour, ignition time will add an additional 2-4 minutes.  
Using the unit in inclement weather with heavy rain could cause longer preheat times.  
If using an extension cord, ensure it is suitable for use outdoors with outdoor appliances. Using the incorrect cord could lead to the cord overheating, melting and/or a drop in voltage.  
While preheating is strongly recommended for best results, you can skip it by pressing and holding the START/STOP button for 3 seconds. "ADD FOOD" will flash across the screen. Open the lid and place ingredients in unit. Once the lid is closed, cooking will begin and the timer will start counting down.
- **Can I turn off Woodfire Flavour technology?**  
If you pressed Woodfire Flavour technology and already started your cooking function by pressing START, you can press the Woodfire Flavour technology button again to turn it off if the ignition cycle is less than 75% complete (indicated by the progress bar on the display screen). If pellets have fully ignited and the grill has transitioned to the preheat cycle (indicated on the display screen), you cannot turn Woodfire Flavour technology off.
- **Can I add more pellets during a cook cycle?**  
When using the SMOKER function, you can add more pellets once the first batch has fully burned. Press and hold the Woodfire Flavour technology button for 4 seconds to ignite new full box of pellets. If running back-to-back smoking sessions, we recommend refilling the smoke box using the pellet scoop when half the pellets have burned. **DO NOT** refill more than 2 times. **DO NOT** re-ignite pellets.