

NINJA

Foodi Grill & Air Fryer

EG351UK

INSTRUCTIONS



THANK YOU

for purchasing the Ninja Grill & Air Fryer



REGISTER YOUR PURCHASE

 ninjakitchen.co.uk/register-guarantee

 Scan QR code using mobile device

RECORD THIS INFORMATION

Model Number: _____

Serial Number: _____

Date of Purchase: _____
(Keep receipt)

Store of Purchase: _____

TECHNICAL SPECIFICATIONS

Voltage: 220-240V- 50-60 Hz

Watts: 1760W



TIP: You can find the model and serial numbers on the QR code label on the back of the unit by the power cord.



This marking indicates this product should not be disposed of with other household waste. To prevent possible harm to the environment or human health from uncontrolled waste disposal, recycle it responsibly to promote the sustainable reuse of material sources. To return your used device, please use the return and collection systems or contact the retailer where this product was purchased. They can take this product for environmentally safe recycling.

CONTENTS

Important Safety Instructions	4
Parts	6
Getting to Know your Ninja Foodi Air Grill	7
Function Buttons	7
Operating Buttons	7
Before First Use	7
Using the Ninja Foodi Smart Grill	8
Splatter Guard	8
Grill Control Technology	8
Using the Probe	9
Using the Probe in Different Scenarios	10
How to Correctly Insert the Probe	11
Cooking Functions	12
Grill	12
Air Fry	12
Roast	13
Bake	14
Dehydrate	14
Reheat	15
Cleaning the Ninja Foodi Grill & Air Fryer	16
Replacement Parts	16
Troubleshooting	17
Warranty	18

IMPORTANT SAFETY INSTRUCTIONS

INDOOR HOUSEHOLD USE ONLY • READ ALL INSTRUCTIONS BEFORE USE

To reduce the risk of injury, fire, electrical shock or property damage, basic safety precautions must always be followed, including the following numbered warnings and subsequent instructions. Do not use appliance for other than intended use

⚠ WARNING

- 1 To eliminate a choking hazard for young children, discard all packaging materials immediately upon unpacking.
- 2 This appliance can be used by persons with reduced physical, sensory or mental capabilities or lack of experience and knowledge if they have been given supervision or instruction concerning use of the appliance in a safe way and understand the hazards involved.
- 3 Keep the appliance and its cord out of reach of children. **DO NOT** allow the appliance to be used by children. Close supervision is necessary when used near children.
- 4 To reduce the risk of fire, **DO NOT** place appliance on stovetop or on hot surfaces.
- 5 **DO NOT** place in heated oven.
- 6 This appliance is for household use only. **DO NOT** use this appliance for anything other than its intended use. **DO NOT** use in moving vehicles or boats. **DO NOT** use outdoors. Misuse may cause injury.
- 7 Ensure the surface is level, clean and dry. **DO NOT** place the appliance near the edge of a countertop during operation.
- 8 **ALWAYS** ensure the appliance is properly assembled before use.
- 9 When using this appliance, provide at least 15.2cm of space above and on all sides for air circulation.
- 10 **DO NOT** use an extension cord. A short power-supply cord is used to reduce the risk of children grabbing the cord or becoming entangled and to reduce the risk of people tripping over a longer cord.
- 11 To protect against electrical shock **DO NOT** immerse cord, plugs, or main unit housing in water or other liquid.
- 12 **DO NOT** use the appliance if there is damage to the power cord or plug. Regularly inspect the appliance and power cord. If the appliance malfunctions or has been damaged in any way, immediately stop use and call Customer Service.
- 13 **NEVER** use socket below countertop surface.
- 14 **DO NOT** place appliance and let cord hang over edges of tables, counters or touch hot surfaces.
- 15 Only use recommended accessories included with this appliance or authorized by SharkNinja. The use of accessories or attachments not recommended by SharkNinja may cause a risk of fire or injury.
- 16 Before placing any accessory into the cooker, ensure they are clean and dry.
- 17 **DO NOT** use the appliance without the removable cooking pot and splatter guard installed.
- 18 **ALWAYS** ensure lid is fully closed before operating.
- 19 **DO NOT** move the appliance when in use.
- 20 **DO NOT** cover the air intake vent or air outlet vent while unit is operating. Doing so will prevent even cooking and may damage the unit or cause it to overheat.
- 21 **DO NOT** touch hot surfaces. Appliance surfaces are hot during and after operation. To prevent burns or personal injury, **ALWAYS** use protective hot pads or insulated oven mitts and use available handles and knobs.
- 22 **DO NOT** touch accessories during or immediately after cooking. The grill plate and crisper plate becomes extremely hot during the cooking process. Avoid physical contact while removing the accessory from the appliance. To prevent burns or personal injury **ALWAYS** use care when interfacing with product. Recommend use of long handed utensil and protective hot pads or insulated oven mitts.
- 23 **DO NOT** use this appliance for deep-frying.
- 24 The Probe does **NOT** replace an external food probe.
- 25 To prevent possible illness, **ALWAYS** use an external food probe to check that your food is cooked to the recommended temperatures
- 26 Should a grease fire occur or the unit emits black smoke, unplug immediately. Wait for smoking to stop before removing any cooking accessories.

- 27 Please refer to the Cleaning & Maintenance section for regular maintenance of the appliance.
- 28 To disconnect, turn unit to "off", then unplug from socket when not in use and before cleaning.
- 29 Allow to cool before cleaning, disassembly, putting in or taking off parts and storage.
- 30 **DO NOT** clean with metal scouring pads. Pieces can break off the pad and touch electrical parts, creating a risk of electric shock.
- 31 Cleaning and user maintenance shall not be made by children.
- 32 Extreme caution must be used when moving an appliance containing hot oil or other hot liquids.
- 33 **DO NOT** place appliance on hot surfaces, near hot gas or electric burner, in a heated oven, or on a stovetop.
- 34 Appliances are not intended to be operated by means of an external timer or separate remote-control system.

SAVE THESE INSTRUCTIONS



Indicates to read and review instructions to understand operation and use of product.



Indicates the presence of a hazard that can cause personal injury, death or substantial property damage if the warning included with this symbol is ignored.



Take care to avoid contact with hot surface. Always use hand protection to avoid burns.



For indoor and household use only.



Do not immerse in water

PARTS

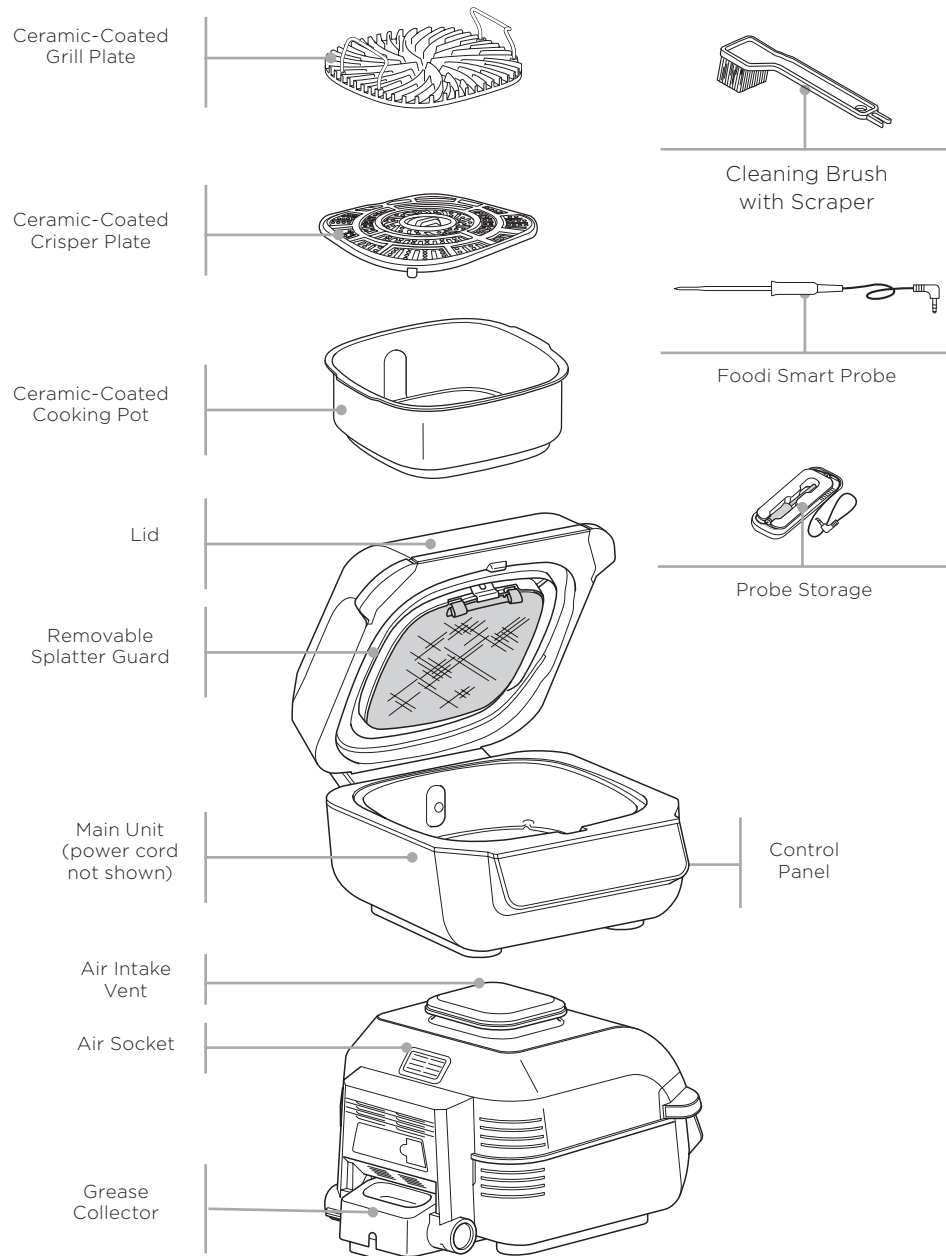

NOTE: Additional accessories are available for purchase at ninjakitchen.co.uk

GETTING TO KNOW THE NINJA FOODI

FUNCTIONS

GRILL: Grill indoors while creating even char, grill marks and grilled flavour.

AIR Fry: For crispiness and crunch with little to no oil.

BAKE: Bake cakes, treats, desserts, and more.

ROAST: Tenderise meats, roast vegetables, and more.

DEHYDRATE: Dehydrate meats, fruits, and vegetables for healthy snacks.

OPERATING BUTTONS

POWER button: Once the unit is plugged in, press the power button to turn on the unit. Pressing it during cooking stops the current cooking function and turns off the unit.

FUNCTION: Press to scroll through and select functions.

NOTE: To adjust the temperature or time during cooking, press the up and down arrows. The unit will then resume at those settings.

Left arrows: Use the up and down arrows to the left of the display to adjust the cooking temperature for any function or, with some models, to set the internal doneness after using PRESET or MANUAL button.

Right arrows: Use the up and down arrows to the right of the display to adjust the cook time or, with some models, to set the food type when using PRESET.

MANUAL setting: Pressing the probe button twice switches the display screen so you can manually set the probe internal doneness.

PRESET setting: Switches the display screen so you can set the probe, food type, and internal doneness.

START/STOP button: After selecting temperature and time, press the START/STOP button to begin cooking.

Standby Mode: If there has been no interaction with the control panel for 10 minutes and the unit is not cooking, the unit will go into Standby Mode and the control panel will dim.

PREHEAT setting: If the unit is preheating, it will be indicated by a progress bar on the display screen. To skip preheat (not recommended), press the button while the grill is in preheat state. ADD FOOD will display.

BEFORE FIRST USE

- 1 Remove all packaging material, promotional labels and tape from the unit.
- 2 Remove all accessories from the package and read this instruction booklet carefully. Please pay particular attention to operational instructions, warnings, and important safety instructions to avoid any injury or property damage.
- 3 Wash the grill plate, splatter guard, crisper plate, probe, cleaning brush and cooking pot in warm, soapy water, then rinse and dry thoroughly.
- 4 When using this appliance, provide at least 15cm of space above and on all sides for air circulation.

USING THE NINJA FOODI

SPLATTER GUARD

Located on the underside of the lid, the splatter guard helps keep the heating element clean.

ALWAYS ensure the splatter guard is installed when cooking. Failure to use the splatter guard will result in oil buildup on the heating element, which can cause smoking.

Removing the splatter guard

Remove the splatter guard for cleaning after every use. Once the splatter guard has cooled completely, remove it by pushing the upper left tab toward the back of the lid. This will release the splatter guard, allowing you to remove it.

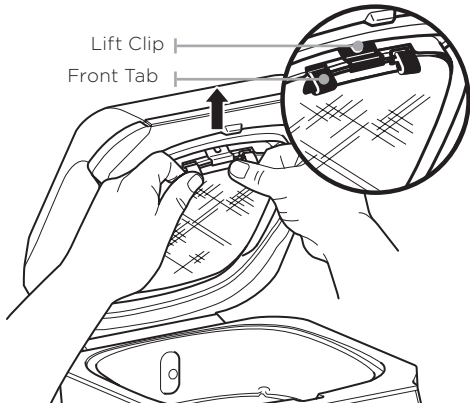

Installing the splatter guard

To install, insert the splatter guard so the grooves on the splatter guard ring match those of the fixed heat guard ring notch on the right. Then gently push the splatter guard upward until it clicks into the tab on the left side.

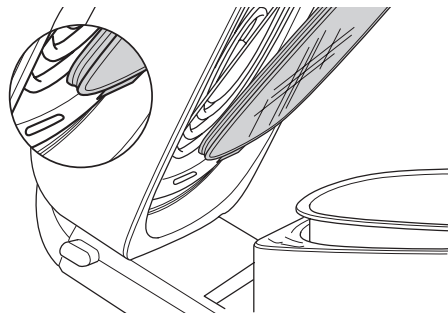

GRILL CONTROL TECHNOLOGY

When using the Grill function, you will need to select the grill plate temperature setting. Below are recommended temperature levels for common ingredients.

LO (200°C)	MED (240°C)	HI (260°C)	MAX (up to 265°C)
<ul style="list-style-type: none"> Bacon Sausages When using thick BBQ sauce 	<ul style="list-style-type: none"> Frozen meats Marinated/ sauced meats 	<ul style="list-style-type: none"> Steaks Chicken Burgers Meat kebabs 	<ul style="list-style-type: none"> Veggies Fruit Pizzas Fresh/ frozen seafood Veggie Kebabs

NOTE: For less smoke, we recommend using Groundnut, Refined Coconut, Avocado, Vegetable or Rapeseed oil instead of olive oil. Heating oil past its smoke point can impart food with a burnt, acrid flavour.

NOTE: The unit may produce smoke when cooking ingredients on a hotter setting than what is recommended. For more cooking charts, refer to your Inspiration Guide or visit ninjakitchen.co.uk.

Switching to Grill after using another function

If the unit is already warm from using a different function, "ADD FOOD" may appear on the screen immediately. We recommend allowing the grill plate to heat up for at least 6 minutes before placing ingredients on it.

Batch grilling

When grilling more than two consecutive batches of food, it is recommended that you empty the fat/oil from the removable cooking pot. It is also HIGHLY recommended to clean the splatter guard in between uses. This will help prevent grease from burning and causing smoke.

If you would like to skip the Preheat process, press the PREHEAT button.

USING THE PROBE

IMPORTANT: DO NOT place hands near Probe cord when in use to prevent burning or scalding

Before First Use

Make sure the probe jack is free of any residue and the cord is free of knots before plugging it into the jack.

- 1 Unwind the cord from the magnetic storage compartment to remove the probe.
- 2 Plug the probe into the jack of the right side of the control panel. Push firmly on the plug until it cannot go into the jack any further. Place the storage compartment back onto the side of the unit.
- 3 Once the probe is plugged into the jack, it will enable and illuminate PRESET and MANUAL. Select the desired cook function by pressing FUNCTION and cook temperature.

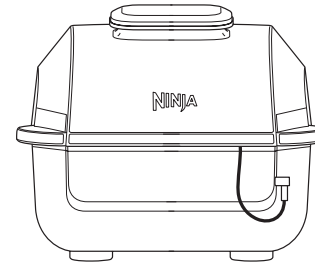

- 4 Press the probe button (⊖) to fully illuminate PRESET and use the arrows to the right of the display to select your desired food type and the arrows to the left of the display to set the internal doneness of your food (Rare through Well).

NOTE: There is no need to set a cook time, as the unit will automatically turn off the heating element and alert you when your food has finished cooking.



To use the MANUAL function instead of PRESET, press the probe button (⊖) again to switch to MANUAL. Use the recommended internal cook temperatures below:

FOOD TYPE:	SET DONENESS TO:
Fish	Medium (55°C)
	Medium Well (60°C)
	Well Done (65°C)
Chicken/Turkey	Well Done (75°C)
Pork	Medium (55°C)
	Medium Well (65°C)
	Well Done (70°C)
Beef/Lamb	Rare (50°C)
	Medium Rare (55°C)
	Medium (60°C)
	Medium Well (65°C)
	Well Done (70°C)

NOTE: Set doneness for BEEF/LAMB are lower than normal recommendations as unit will carry-over cook 5-10°C

- 5 Place the accessory required (excluding the probe) for your selected cook function in the unit and close the lid. Press START/STOP to begin preheating.

NOTE: Refer to the UK Food Standards Agency for recommended food safe temperatures.

USING THE NINJA FOODI – CONT.

- While the unit is preheating, insert the probe horizontally into the centre of the thickest part of the piece of protein. **Refer to the chart on the adjacent page on further probe placement instructions.**
- When the unit has preheated and “ADD FOOD” appears on the screen, open the lid, place food with inserted probe in the unit, and close the lid over the probe cord.
- The progress bar at the top of the display will track doneness. It will start flashing at the lowest doneness and progress to the set doneness.

RARE > MED RARE < MED MED WELL WELL

NOTE: When using Roast and Grill, the unit will beep and display FLIP. Flipping is optional, but recommended.

- The unit will automatically stop when desired doneness is almost reached, as it accounts for carry-over cooking, and “GET FOOD” will display on the screen.







⬆️ ⬆️ GET FOOD ⬆️ ⬆️

- Transfer the protein to a plate while “REST” displays on the screen. Probe does not need to still be inserted. The protein will continue to carry-over cook to your set doneness, which will take about 3–5 minutes. This is an important step, as not resting could lead to results looking less cooked. Carry-over cook times can vary based on type, cut and size of protein.

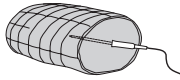
NOTE: To check the internal temperature of other pieces of protein, press and hold the probe button and insert the probe into each piece of meat.

NOTE: The probe will be HOT. Use either oven mitts or tongs to take the probe out of the protein.

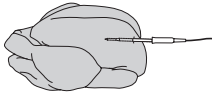
HOW TO CORRECTLY INSERT THE PROBE

FOOD TYPE:	PLACEMENT	CORRECT	INCORRECT
Steaks Pork chops Lamb chops Chicken breasts Burgers Tenderloins Fish fillets	<ul style="list-style-type: none"> Insert probe horizontally into the centre of the thickest part of the meat. Make sure the probe is close to (but not touching) the bone and away from any fat or gristle. Make sure the tip of the probe is inserted straight into the centre of the meat, not angled toward the bottom or top of it. <p>NOTE: The thickest part of the fillet may not be the centre. It is important that the end of the probe hits this area so that desired results are achieved.</p>	 	 
Whole chicken	<ul style="list-style-type: none"> Insert probe horizontally into the thickest part of the breast, parallel to, but not touching, the bone. Make sure the tip reaches the centre of the thickest part of the breast and doesn't go all the way through the breast into the cavity. 		

NOTE: DO NOT use the probe with frozen protein or for cuts of meat thinner than 1.5cm.

USING THE NINJA FOODI - CONT.

COOKING FUNCTIONS

Plug in the unit and press the power  button to turn it on.

Grill

- 1 Place the cooking pot in the unit with the indent on the pot aligned with the bump on the main unit. Then place the grill plate in the pot with handles facing up. Ensure the splatter guard is in place, then close the lid.

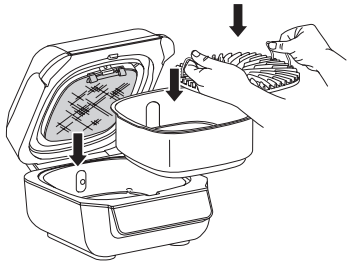

- 2 Press the GRILL button. The default temperature setting will display. Use the set of arrows to the left of the display to adjust the temperature up to MAX.
- 3 If using the Foodi® Smart Probe, refer to the Using the Probe section. If not using the probe, use the set of arrows to the right of the display to adjust the cook time, in 1-minute increments, up to 30 minutes.
- 4 Press START/STOP to begin preheating. The progress bar will begin illuminating. It will take approximately 10 minutes for the unit to preheat.
- 5 When preheating is complete, the unit will beep and "ADD FOOD" will appear on the display.

NOTE: If your model has a cooking probe and you would like to use it to check your food's internal doneness, press the probe button  for 2 seconds and the food's internal temperature will appear on the screen. Press and hold button again to exit mode.

- 6 Open the lid and place ingredients on the grill plate. Once the lid is closed, cooking will begin and the timer will start counting down.
- 7 When cook time is complete, the unit will beep and END will appear on the display.

NOTE: If batch cooking, refer to page 8 for instructions.

Air Fry

- 1 Place cooking pot in the unit with the indent on the pot aligned with the bump on the main unit. Place the crisper plate in the pot. Ensure the splatter guard is in place, then close the lid.

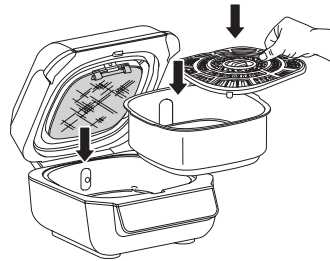

- 2 Press the AIR FRY button. The default temperature setting will display. Use the set of arrows to the left of the display to adjust the temperature up to 200°C.
- 3 If using the Probe, refer to the Using the Probe section. If not using the probe, use the set of arrows to the right of the display to adjust the cook time, in 1-minute increments, up to 1 hour.
- 4 Press START/STOP to begin preheating. The progress bar will begin illuminating. It will take approximately 3 minutes for the unit to preheat.
- 5 When preheating is complete, the unit will beep and "ADD FOOD" will appear on the display.
- 6 Open the lid and place ingredients in the crisper plate. Once the lid is closed, cooking will begin and the timer will start counting down.

NOTE: While preheating is strongly recommended for best results, you can skip it by pressing the SKIP PREHEAT button. "ADD FOOD" will appear on the display. Open the lid and place ingredients in the crisper plate. Once the lid is closed, cooking will begin and the timer will start counting down.

- 7 When you open the lid, the unit will pause. Use silicone-tipped tongs to mix the food on the crisper plate. When done, close the lid and cooking will automatically resume.
- 8 When cook time is complete, the unit will beep and END will appear on the display.

Roast

- 1 Place cooking pot in the unit with the indent on the pot aligned with the bump on the main unit. Ensure the splatter guard is in place, then close the lid.

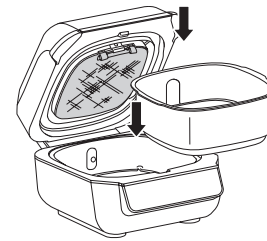

- 2 Press the ROAST button. The default temperature setting will display. Use the set of arrows to the left of the display to adjust the temperature up to 220°C.

NOTE: Convert traditional oven recipes by reducing the temperature by 20°C. Check food frequently to avoid overcooking.

- 3 If using the Probe, refer to the Using the Probe section. If not using the probe, use the set of arrows to the right of the display to adjust the cook time, in 1-minute increments up to 1 hour and 5-minute increments from 1 to 4 hours.
- 4 Press START/STOP to begin preheating. The progress bar will begin illuminating. It will take approximately 3 minutes for the unit to preheat.

NOTE: While preheating is strongly recommended for best results, you can skip it by pressing the SKIP PREHEAT button. "ADD FOOD" will appear on the display. Open the lid and place ingredients in the cooking pot. Once the lid is closed, cooking will begin and the timer will start counting down.

- 5 When preheating is complete, the unit will beep and "ADD FOOD" will appear on the display.
- 6 Open the lid and place ingredients in the pot. Once the lid is closed, cooking will begin and the timer will start counting down.

NOTE: If you want to check the doneness of your food, press the probe button  for 2 seconds and the food's internal temperature will appear on the screen. Press and hold button again to exit mode.

- 7 When cook time is complete, the unit will beep and END will appear on the display.

USING THE NINJA FOODI - CONT.

Bake

- 1 Place cooking pot in the unit with the indent on the pot aligned with the bump on the main unit. Ensure the splatter guard is in place, then close the lid.

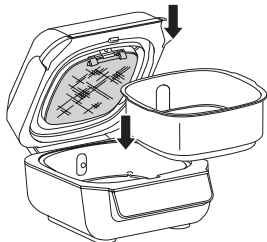

- 2 Press the BAKE button. The default temperature setting will display. Use the set of arrows to the left of the display to adjust the temperature up to 200°C.

NOTE: Convert traditional oven recipes by reducing the temperature by 20°C. Check food frequently to avoid overcooking.

- 3 If using the Foodi® Smart Probe refer to the Using the Probe section. If not using the probe, use the set of arrows to the right of the display to adjust the cook time, in 1-minute increments, up to 1 hour and in 5-minute increments from 1 to 2 hours.
- 4 Press START/STOP to begin preheating. The progress bar will begin illuminating. It will take approximately 3 minutes for the unit to preheat.

NOTE: While preheating is strongly recommended for best results, you can skip it by pressing the SKIP PREHEAT button. "ADD FOOD" will appear on the display. Open the lid and place ingredients in the crisper plate. Once the lid is closed, cooking will begin and the timer will start counting down.

- 5 When preheating is complete, the unit will beep and "ADD FOOD" will appear on the display.
- 6 Open the lid and add ingredients to the pot or set the bake pan directly in the pot, and close the lid to start cooking. Once the lid is closed, cooking will begin and the timer will start counting down.

NOTE: If you would like to use the probe to check your food's internal doneness, press the probe button  for 2 seconds and the food's internal temperature will appear on the screen. Press and hold button again to exit mode.

- 7 When cook time is complete, the unit will beep and END will appear on the display.

Dehydrate

- 1 Place cooking pot in the unit with the indent on the pot aligned with the bump on the main unit. Place a single layer of ingredients in the pot. Then place the crisper plate in the pot on top of the ingredients and add another layer of ingredients to the plate. Ensure the splatter guard is in place, then close the lid.

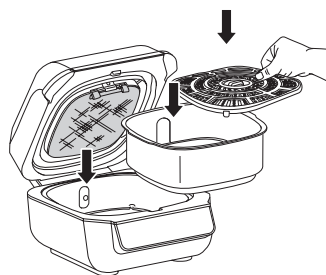

- 2 Press the DEHYDRATE button. The default temperature setting will display. Use the set of arrows to the left of the display to adjust the temperature up to 90°C.
- 3 Use the set of arrows to the right of the display to adjust the dehydration time, in 15-minute increments, up to 12 hours.
- 4 Press START/STOP to begin. (The unit does not preheat in Dehydrate mode.)
- 5 When dehydration time is complete, the unit will beep and END will appear on the display.

CLEANING YOUR NINJA FOODI

The unit should be cleaned thoroughly after every use. Always let the appliance cool before cleaning.

- Unplug the unit from the plug socket before cleaning. Keep the lid open after removing your food to allow the unit to cool quicker.
- All accessories should hand-washed only. Cleaning any accessories or parts in the dishwasher may result in damage.
- When hand-washing, we recommend using the included cleaning brush to help wash the parts. Use the opposite end of the cleaning brush as a scraper to assist with releasing baked-on sauces or cheese. Air-dry or towel-dry all parts after hand-washing.

NOTE: DO NOT use washing up liquid on or near the probe jack. We recommend using compressed air or a cotton swab to avoid damaging the jack.

STORAGE TIP: When stacking the coated accessories to store place a cloth or paper towel between each piece to protect the coated surfaces.

- If food residue or grease are stuck on the grill plate, splatter guard, or any other removable part, soak in warm soapy water before cleaning.
- Clean the splatter guard after every use. Soaking the splatter guard overnight will help soften the baked-on grease. After soaking, use the cleaning brush to remove the grease from the stainless steel frame and front tabs.
- Deep clean the splatter guard by putting it in a pot of water and boiling it for 10 minutes. Then, rinse with room temperature water and allow to dry completely.
- The Probe and holder are handwash with a damp cloth only. Never place unit or probe in dishwasher or submerge in liquid of any kind.

NOTE: NEVER use abrasive tools or cleaners. **NEVER** immerse the main unit in water or any other liquid.

REPLACEMENT PARTS

To order additional parts and accessories, visit ninjakitchen.co.uk or contact Customer Service at 0800 862 0453. So we may better assist you, please Register your product online at ninjakitchen.co.uk/registerguarantee have the product on hand when you call.

TROUBLESHOOTING

- **“Add Food” appears on the control panel display.**
The unit has completed preheating and it is now time to add your ingredients.
- **“Shut Lid” appears on the control panel display.**
The lid is open and needs to be closed for the selected function to start.
- **“Plug In” appears on the control panel display.**
The probe is not plugged into the jack on the right side of the control panel. Plug the probe in before proceeding. Press the probe in until you hear a click.
- **“PRBE ERR” appears on the control panel display.**
This means the unit timed out before food reached the set internal temperature. As a protection for the unit, it can run for only certain lengths of time at specific temperatures.
- **“E” appears on the control panel display.**
The unit is not functioning properly. Contact Customer Service at 0800 862 0453. So we may better assist you, please register your product online at ninjakitchen.co.uk/registerguarantee and have the product on hand when you call.
- **Why is my food overcooked or undercooked even though I used the probe?**
It is important to insert the probe lengthwise into the thickest part of the ingredient to get the most accurate reading. Make sure to allow food to rest for 3-5 minutes to complete cooking. For more information, refer to the Using the Foodi® Smart Probe section.
- **Why does the preheat progress bar not start from the beginning?**
When the unit is warm from previously being used, it will not require the full preheating time.
- **Can I cancel or override preheating?**
Preheating is highly recommended for best results, but you can skip it by selecting the PREHEAT button after you press the START/STOP button.
- **Should I add my ingredients before or after preheating?**
For best results, let the unit preheat before adding ingredients.
- **Why is my unit emitting smoke?**
When using the Grill function, always select the recommended temperature setting. Recommended settings can be found in the Inspiration Guide. Make sure the splatter guard is installed.
- **How do I pause the unit so I can check my food?**
When the lid is opened during a cooking function, the unit will automatically pause.
- **Will the probe grip melt if it touches the hot grill plate?**
No, the grip is made of a high-temperature silicone that can handle the Ninja Foodi Grill's high temperatures.
- **My food is burned.**
Do not add food until recommended preheat time is complete. For best results, check progress throughout cooking, and remove food when desired level of brownness has been achieved. Remove food immediately after the cook time is complete to avoid overcooking.
- **Why does the unit have a 1-9 scale for the Beef Preset?**
Perception of what a specific internal doneness looks like differs from person to person, even restaurant to restaurant. The 1-9 scale provides a wide range of options for each doneness level so you can customize doneness to your liking.

MANUFACTURER'S GUARANTEE

The Ninja 2 Year Guarantee

When a consumer buys a product in the UK, they get the benefit of legal rights relating to the quality of the product (your "legal rights"). You can enforce your legal rights against your retailer, including Ninja if you bought your Ninja kitchen appliance from ninjakitchen.co.uk. However, at Ninja we are so confident about the quality of our products that we give the owner an additional, free parts and labour manufacturer's guarantee of up to 2 years.

The guarantee it comes with is an important consideration - and reflects how much confidence the manufacturer has in its product and manufacturing quality.

The manufacturer's guarantee does not affect your legal rights.

How long are new Ninja machines guaranteed for?

Our manufacturer's guarantee lasts for one year from the date of purchase as standard, or for two years if you register your purchase with us within 28 days.

How do I register my Ninja guarantee?

If you have purchased your Ninja kitchen appliance directly from ninjakitchen.co.uk your guarantee is registered automatically. If you bought it from anywhere else in the UK, you can register your guarantee online within 28 days of purchase.

- To register online, please visit www.ninjakitchen.co.uk/register-guarantee or scan the QR code on the back cover.
- Keep a note of the date you purchased the machine.

IMPORTANT:

- Keep your receipt if you bought your Ninja kitchen appliance from anywhere except ninjakitchen.co.uk. You will need it to claim under your guarantee.
- The free Ninja guarantee only applies in the UK.

What are the benefits of registering my free Ninja guarantee?

When you register your guarantee, you will get an extra year of cover. We'll also have your details to hand if we ever need to get in touch. If you further agree to receive communications from us, you can also receive tips and advice on how to get the best out of your Ninja kitchen appliance and hear the latest news about new Ninja technology and launches.

What is covered by the free Ninja guarantee?

Repair or replacement (at Ninja's discretion) of your Ninja machine, including all parts and labour.

What is not covered by the free Ninja guarantee?

- Normal wear and tear.
- Accidental damage or faults caused by negligent use or care, misuse, neglect, careless operation or handling of the Ninja kitchen appliance which is not in accordance with the Ninja Operating Manual supplied with your machine.
- Damage caused by use of the Ninja kitchen appliance for anything other than normal domestic household purposes.
- Damage caused by use of parts not assembled or installed in accordance with the operating instructions.

- Damage caused by use of parts and accessories which are not Ninja Genuine Components
- Faulty installation (except where installed by Ninja).
- Repairs or alterations carried out by parties other than Ninja or its agents.

How can I claim under the free Ninja guarantee?

Contact our customer service helpline on 0800 862 0453. For service hours please visit our website under 'Contact Us'. It's free to call, and you'll be put straight through to a Ninja representative. You'll also find online support at <https://support.ninjakitchen.co.uk/>. The Ninja representative will go through some troubleshooting with you, and if we conclude that the item has failed, we will send you a replacement part or a returns label to send the defective item back to us free of charge. When you have delivered the defective product to us, we will send you a replacement.

Please remember that the item will need to be boxed when you return it to us. It can be any suitable box, it does not have to be the original packaging.

Where can I buy genuine Ninja spares and accessories?

Ninja spares and accessories are developed by the same engineers who developed your Ninja kitchen appliance. You'll find a full range of Ninja spares, replacement parts and accessories for all Ninja machines at www.ninjakitchen.co.uk. Please remember that damage caused by the use of non-Ninja spares may not be covered under your guarantee.

NINJA

Foodi

Grill & Air Fryer

**SharkNinja Europe Ltd,
1st/2nd Floor Building 3150,
Thorpe Park, Century Way,
Leeds, England,
LS15 8ZB
ninjakitchen.co.uk**

**SharkNinja Germany GmbH,
Rotfeder-Ring 9,
60327 Frankfurt am Main,
Germany
ninjakitchen.eu**

Illustrations may differ from actual product. We are constantly striving to improve our products, therefore the specifications contained herein are subject to change without notice.

NINJA, FOODI, and NINJA FOODI are registered trademarks in the United Kingdom of SharkNinja Operating LLC.

© 2024 SharkNinja Operating LLC

